

## PEES Power Systems

# Energy storage cabinet exhaust fan installation



## Energy storage cabinet exhaust fan installation

---



### Using liquid air for grid-scale energy storage

Liquid air energy storage could be the lowest-cost solution for ensuring a reliable power supply on a future grid dominated by carbon-free yet intermittent energy sources, according to a new model from MIT ...

### New materials could boost the energy efficiency of microelectronics

MIT researchers developed a new fabrication method that could enable them to stack multiple active components, like transistors and memory units, on top of an existing circuit, which would improve the ...

#### ESS



### Making clean energy investments more successful

New research emphasizes the importance of well-validated models and forecasting tools in evaluating choices for investments in clean energy technologies and policies by governments and companies.



## Unlocking the hidden power of boiling -- for energy, space, and beyond

Unlocking its secrets could thus enable advances in efficient energy production, electronics cooling, water desalination, medical diagnostics, and more. "Boiling is important for applications way beyond

...



 LFP 12V 200Ah

## MIT Energy Initiative conference spotlights research priorities amidst

At the MIT Energy Initiative's Annual Research Conference, industry leaders agreed collaboration is key to advancing critical technologies amidst a changing energy landscape.

## A new approach could fractionate crude oil using much less energy

MIT engineers developed a membrane that filters the components of crude oil by their molecular size, an advance that could dramatically reduce the amount of energy needed for crude oil fractionation.



## MIT Climate and Energy Ventures class spins out entrepreneurs -- ...

In MIT course 15.366 (Climate and Energy Ventures) student teams select a technology and determine the best path for its commercialization in the energy sector.



## How artificial intelligence can help achieve a clean energy future

A look at how AI can be used to help support the clean energy transition by helping to manage power grid operations, plan infrastructure investments, guide the development of novel materials, and more.



 Efficient Higher Revenue

- Max. Efficiency 97.5%
- Max. PV Input Voltage 600V
- 150% Peak Output Power
- 2 MPP Trackers, 100% DC Input Oversizing
- Max. PV Input Current 15A, Compatible with High Power Modules

 Intelligent Simple O&M

- IP65 Protection Degree: support outdoor installation
- Smart I-V Curve Diagnosis Function: locate PV string faults accurately and automatically detect faults
- DC & AC Type II SPD: prevent lightning damage
- Battery Reverse Connection Protection

 Flexible Abundant Configuration

- Plug & Play, EPS Switching Under 10ms
- Compatible with Lead-acid and Lithium Batteries
- Max. 6 Units Inverters Parallel
- AFCI Function (Optional): when an arc fault is detected the inverter immediately stops operation

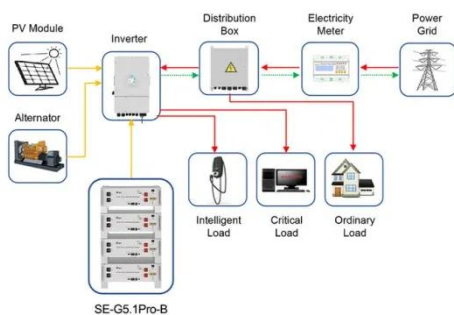

Application scenarios of energy storage battery products

## Explained: Generative AI's environmental impact

MIT News explores the environmental and sustainability implications of generative AI technologies and applications.

## Introducing the MIT-GE Vernova Climate and Energy Alliance

The MIT-GE Vernova Climate and Energy Alliance, a five-year collaboration between MIT and GE Vernova, aims to accelerate the energy transition and scale new innovations.



---

## Contact Us

---

For catalog requests, pricing, or partnerships, please visit:  
<https://www.peregrine-energy.co.za>

