

PEES Power Systems

Cost of 50kW IP54 Outdoor Cabinet for African Mines

LPSB48V400H
48V or 51.2V



Overview

Recent pricing trends show standard industrial systems (50-100kWh) starting at \$25,000 and premium systems (200-500kWh) from \$100,000, with flexible financing options available for businesses. How much does a 50 kWh energy storage battery cost?

The cost of a 50 kWh energy storage battery typically ranges between \$5,000 and \$15,000, depending on several factors including battery technology, installation expenses, and Discover our 50kW solar packages for dependable and efficient energy. AZE's lithium battery energy storage system (BESS) is a complete system design with features like high energy density, battery management, multi-level safety protection, an outdoor cabinet with a modular design. Shandong Harbor Electric Power Engineering Co. Rectifier. The Anker 757 PowerHouse (1.5kWh) fits in a sedan trunk but powers a 1,800W circular saw. Meanwhile, the massive EcoFlow DELTA Pro Ultra (21kWh) can back up entire homes. Pro tip: Match your watt-hours to needs: More panels ≠ faster charging. [pdf] Standard sizes often range from 1 meter to over 3. Cost Effective Battery Energy Storage System 50kw 100kwh Outdoor Energy Storage System for Industrial Commercial, Find Details and Price about Storage Container. Long-Lasting Lithium-Ion Battery: Equipped.

Cost of 50kW IP54 Outdoor Cabinet for African Mines



50kW-100kWh Energy Storage System Outdoor Cabinet Battery as Backup

The cost will depend on a number of factors, including operating duration, utility rate structures, demand charges and additional fees. Please find below calculation methods, examples, and typical ranges for commercial ...

50KW 100KWH OUTDOOR CABINET ENERGY STORAGE SYSTEM

This guide provides step-by-step instructions on how to install your R-BOX-OC outdoor solar battery cabinet, including site selection, assembly, wiring, and system testing. [pdf]



Cost of a 50kW Outdoor Energy Storage Unit for Farms

ICEENG CABINET serves customers in 18+ countries across Africa, providing outdoor communication cabinets, power equipment enclosures, and battery energy storage cabinets for telecommunications, utilities, and ...

50kw 100kwh Outdoor All In One All In One Cabinet Energy

Cost of 50kW Outdoor Photovoltaic Energy Storage Cabinet for Airports 50kW/100kWh outdoor cabinet ESS solution (KAC50DP-BC100DE) is designed for small to medium size of C&I energy storage and microgrid ...



Microgrid System Outdoor Cabinet Type 20kwh 40kwh 50kw 100kwh

Togo Solar Outdoor Energy Storage Cabinet Hybrid Type Equipped with a robust 15kW hybrid inverter and 35kWh rack-mounted lithium-ion batteries, the system is seamlessly housed in an IP55-rated cabinet for ...

50KW 100KWH OUTDOOR CABINET ENERGY STORAGE SYSTEM

Our outdoor energy storage cabinets are built with IP-rated enclosures to withstand harsh environments, making them ideal for both indoor and outdoor deployment.



Kstar 50kW 100kWh ESS

Outdoor Cabinet

High-Performance Energy Storage Solution: The Kstar Kac50dp-bc100de outdoor all-in-one ESS cabinet is designed to provide a reliable and efficient energy storage solution for commercial and industrial applications,

...



Energy Storage Cabinet Outdoor 20KW 50KWh/ 30KW 60KWh

HBOWA PV energy storage systems offer multiple power and capacity options, with standard models available in 20KW 50KWh, 30KW 60KWh, and 50KW 107KWh configurations. You can add many battery modules ...

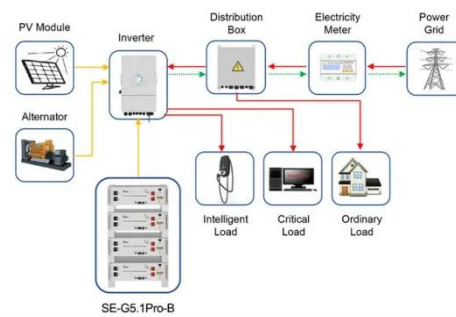

Application scenarios of energy storage battery products

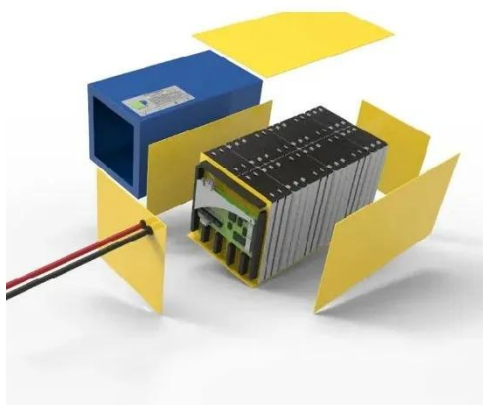

Cost of a 50kW Energy Storage Container for African Mines

On average, the installation costs for a 50kW battery storage system can range from \$10,000 to \$20,000 or more. Integration with existing power systems or renewable energy sources such

High-Performance 50kW 100kWh Outdoor Cabinet Energy Storage ...

Enhance your energy storage capabilities with our cutting-edge 50kW/100kWh outdoor cabinet energy storage system. With a rated AC power of 50kW and a rated capacity of 100kWh, this system boasts a high system ...

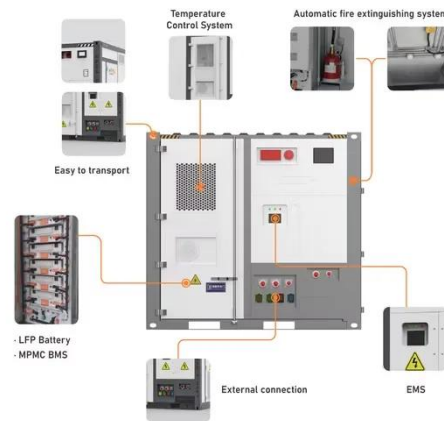

Contact Us

For catalog requests, pricing, or partnerships, please visit:
<https://www.peregrine-energy.co.za>

