

## PEES Power Systems

# Cost analysis of a 25kW photovoltaic energy storage cabinet

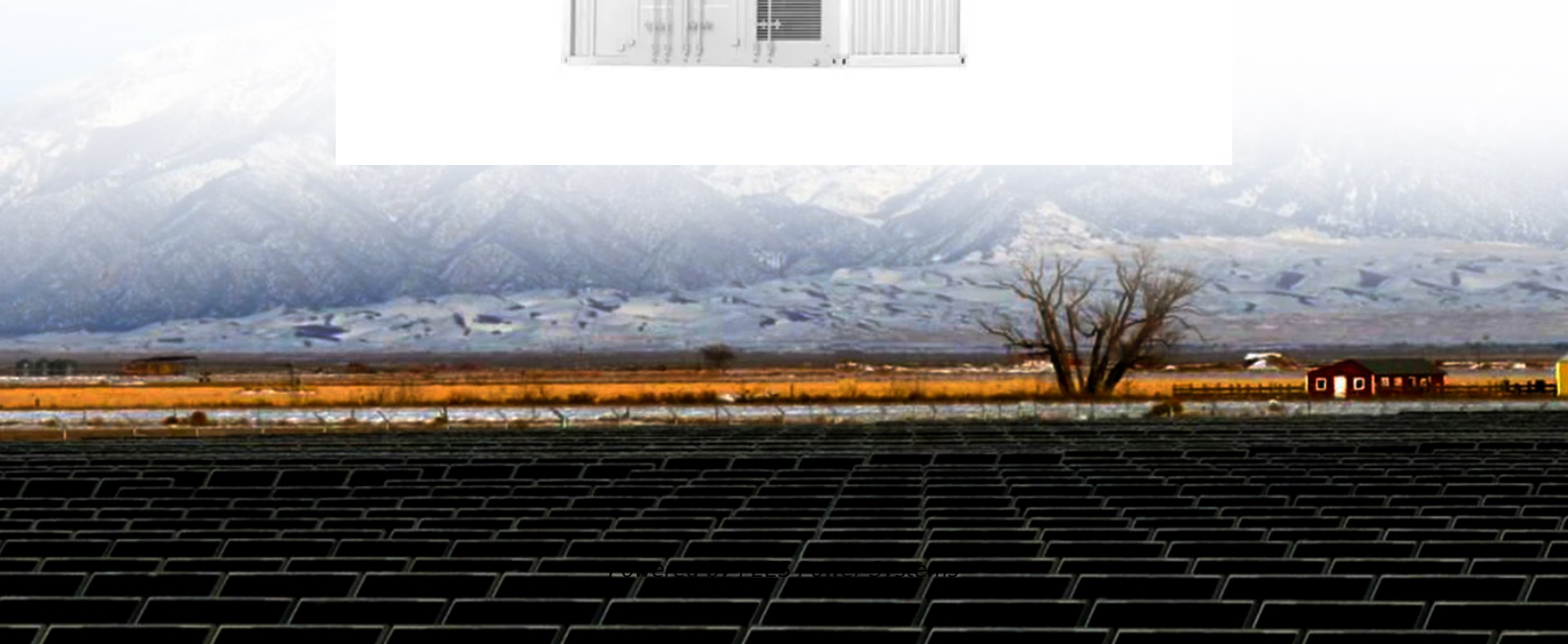
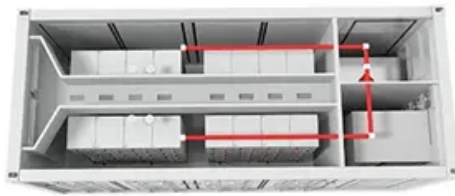

## Cost analysis of a 25kW photovoltaic energy storage cabinet

---



### U.S. Solar Photovoltaic System and Energy Storage Cost

We show bottom-up manufacturing analyses for modules, inverters, and energy storage components, and we model unique costs related to community solar installations. We also account for PV ...

---

### Solar Photovoltaic System Cost Benchmarks

These benchmarks help measure progress toward goals for reducing solar electricity costs and guide SETO research and development programs. Read more to find out how these cost benchmarks are ...



### Energy Storage Cabinet Cost Analysis: What You Need to Know in 2025

Whether you're a factory manager trying to shave peak demand charges or a solar farm operator staring at curtailment losses, understanding storage costs is like knowing the secret recipe ...

## Energy Storage Cabinet Price and Profit Calculation: A ...

Looking to invest in energy storage cabinets but unsure about costs and ROI? This article breaks down pricing factors, profit calculation methods, and industry trends to help businesses make informed ...



2MW / 5MWh  
Customizable



## Solar Installed System Cost Analysis , Solar Market Research

U.S. Solar Photovoltaic System and Energy Storage Cost Benchmarks, With Minimum Sustainable Price Analysis: Q1 2022, NLR Technical Report (2022) Floating Photovoltaic System ...

## ENERGY STORAGE CABINET FIELD AND PRICE ANALYSIS

The price of a photovoltaic energy storage cabinet varies depending on a variety of factors, including its capacity, brand, features, and the technology used. Generally speaking, the price of a photovoltaic ...



## Energy Storage Cabinet Production Cost Analysis:

SUPPORT REAL-TIME ONLINE  
MONITORING OF SYSTEM STATUS

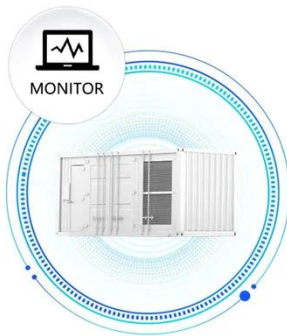

## Breaking Down the

With global energy storage projects requiring 35% cost reductions to meet 2030 decarbonization targets, understanding energy storage cabinet production costs isn't just technical jargon - it's business ...

## 25kw solar system

In this article, we will explore the benefits and costs associated with a 25kw solar system, as well as other important considerations to help you determine whether this setup is the right fit for ...

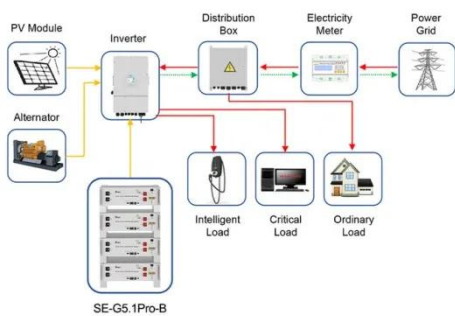

Application scenarios of energy storage battery products

## 25kW Commercial Solar Panels Cost & Options

Learn about the cost of 25kW commercial solar panels and various options in this guide by Nuance Energy.

## How Much Does a 25kW Solar System Cost?

A 25kW solar system is an excellent choice for large homes or businesses with substantial energy needs. This

article will explore the costs associated with a 25kW solar system, factors ...



---

## Contact Us

For catalog requests, pricing, or partnerships, please visit:  
<https://www.peregrine-energy.co.za>

